



1. INTRODUCTION

This SOP is for the handling and storage of CO2 gas cylinders.

2. REQUIREMENTS

2.1 Training/Licensing

This SOP is read concurrently with the University of Melbourne Alcohol Management and Safety Checklist (C&S-modified version).

2.2 Personal Protective Equipment

Close toe shoes required

2.3 Other

CO2 gas cylinders (dangerous goods Class 2.2) must be positioned so the pressure relief valve is in the vapor space of the cylinder – eg stored in an upright position.

Quantities of CO2 gas cylinders stored in one place should be kept as low as is reasonably practicable within the limits of safe storage facilities, and collected and disposed of on a regular basis. CO2 gas cylinders must be handled and stored in accordance with AS 4332-2004: *The storage and handling of gases in cylinders*.

WARNINGS/SPECIAL REQUIREMENTS

CO2 gas is non-flammable, non-toxic gas, class 2.2; unless properly stored and handled, CO2 gas cylinders are a safety risk because they are:

- pressurised, with the risk of a violent release of contents if the container is punctured
- an asphyxiant, if the contents displace the air in an area occupied by humans or animals

CO2 gas is heavier than air and will accumulate in low areas and depressions, rather than dissipate.

DO transport cylinders in the upright position and properly secured to a suitable trolley or designated transport vehicle.

DO NOT transport cylinders with regulators or equipment attached, even if the cylinder valves are closed.

Where possible, AVOID transporting cylinders in a closed vehicle.

If a gas bottle must be transported in a vehicle the safest place is on the floor of the passenger rear seat.

NO gas canister over 10kg may be transported in a car.

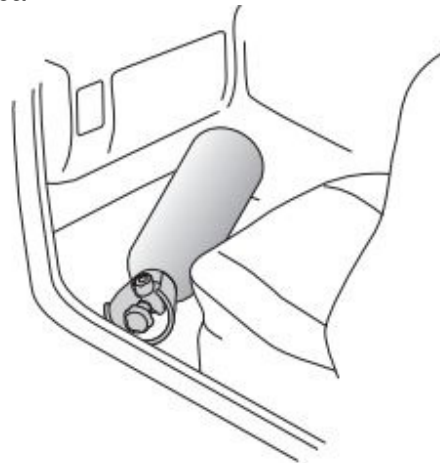

3. OPERATION

4.1 Storage location

Cylinders are to be stored in the gas cage located on the northern side of Union House next to the Loading Bay or in another designated storage area that meets the appropriate storage requirements.

The cage is fitted with signage as required by the AS 4332-2004: *The storage and handling of gases in cylinders*.

3.2 Access to storage

The gas cage is locked at all times, contact Union House security when you require access to the cage.

3.3 Storage and handling of gas cylinders

Cylinders should be placed upright at all times, including within the gas cage.

Cylinders must not be placed on top of each other.

Cylinder must be transported using trolleys, and placed onto the trolley one at a time.

4. MAINTENANCE

5.1 Before Use

Always check bottle for damage.

5.2 After Use

Ensure that the bottle has been turned off completely. To do this, turn the valve clockwise (to the right) until it will turn no more. Place your hand in front of the valve to confirm no gas is escaping.

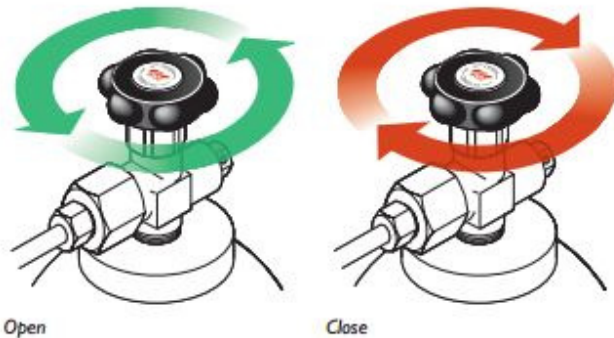

5.3 Scheduled Works

Gas cylinders are replaced by Keg King (or another certified supplier) whenever they are emptied. They carry out any required maintenance on the gas canisters.

6 TROUBLE SHOOTING

If you hear a leak, turn the bottle off immediately. If you believe the bottle is faulty or you cannot stop a leak, vacate the area and contact University Security. Do not reenter area until advised that it is safe to do so. Call the supplier to report the faulty bottle.

7 EMERGENCY

In a medical emergency ring 000, then notify University security: 8344 6666

8 REFERENCES

- Work Health and Safety Act 2011
Work Health and Safety Regulation 2014
AS 4332-2004: *The storage and handling of gases in cylinders*
AS2473.1:2006 – Valves for compressed gas cylinders – Specifications, type testing, and manufacturing tests and inspections
MP 48 – 2007 Certified gas cylinder test stations
Work Health and safety act 2011
Code of practice for risk assessment 2011
Code of practice for OHS consultation 2011
Risk management at work 2011.
BOC publication, “**Guidelines for gas cylinder safety**”
http://www.psych.usyd.edu.au/whs/COP/BOC_Guidelines_for_Gas_Cylinder_Safety.pdf
AVM SOP103 – Trolleys
M:\OHS\Maps\Emergency Exit and Assembly Maps